



safety products

CCI X-Treme Box Temporary Power Distribution Unit with GFCI Protection

CCI X-Treme Box™ Distribution Unit with GFCI Protection

This rugged equipment is designed to safely distribute temporary power in areas such as construction sites and other jobsite environments. UL Listed for outdoor use and designed to stand up to the toughest workplace conditions. The 125V/20A receptacles on the unit are protected by individual GFCI's with "Power On" indicators. They also provide open neutral and reverse phasing protection. Each unit has been carefully assembled to provide the ultimate in electrical safety as well as meeting current OSHA requirements.

The units use a 50A California Standard power inlet that distributes power to seven receptacles and a 50A California Standard pass-thru power outlet for daisy-chaining additional units. In addition to the six 125V/20A receptacles, each unit has one additional non-GFCI NEMA L6-30 turn-lock receptacle rated 250V/30A. Over current protection is provided by a full complement of circuit breakers located under an easy-access side panel.

FEATURES

01960, 01962 (roll cage)

01970, 01972 (roll cage) – straight blades

- ▶ 1 – 125/250V/50A Input
- ▶ 1 – 125/250V/50A Pass-thru
- ▶ 6 – 125V/20A NEMA 5-20R GFCI
- ▶ 1 – 250V/30A NEMA L6-30R Non-GFCI
- ▶ GFCI Trip Level: 4-6mA
- ▶ ETL Listed to UL1640 and CAN/CSA C22.22 No. 14
- ▶ Dimensions 14.5"W x 21"L x 11"H

Made to meet
OSHA
Specifications



Made in USA



01960



01962

CCI Xtreme Box™ Distribution Unit Model 01962 Wiring Diagram

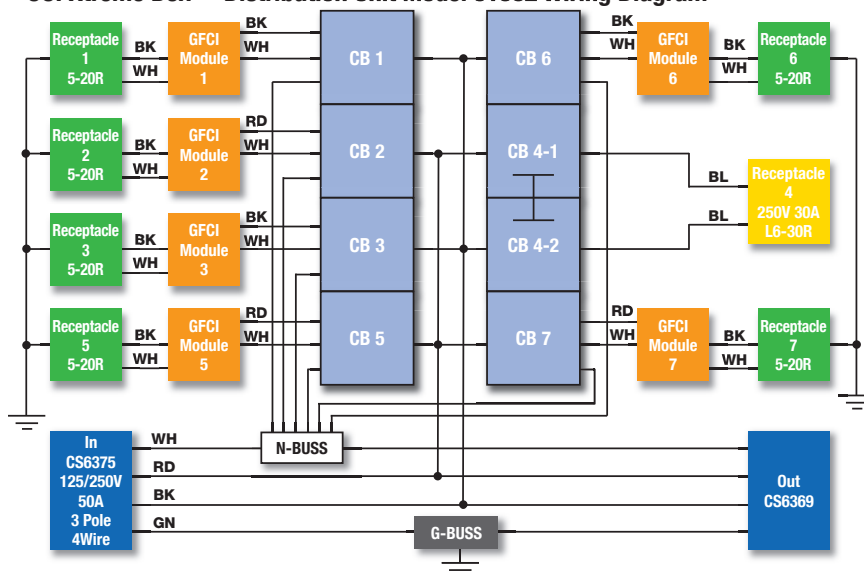

Coleman Cable Inc.

800.323.9355 • www.colemancable.com